

F 635

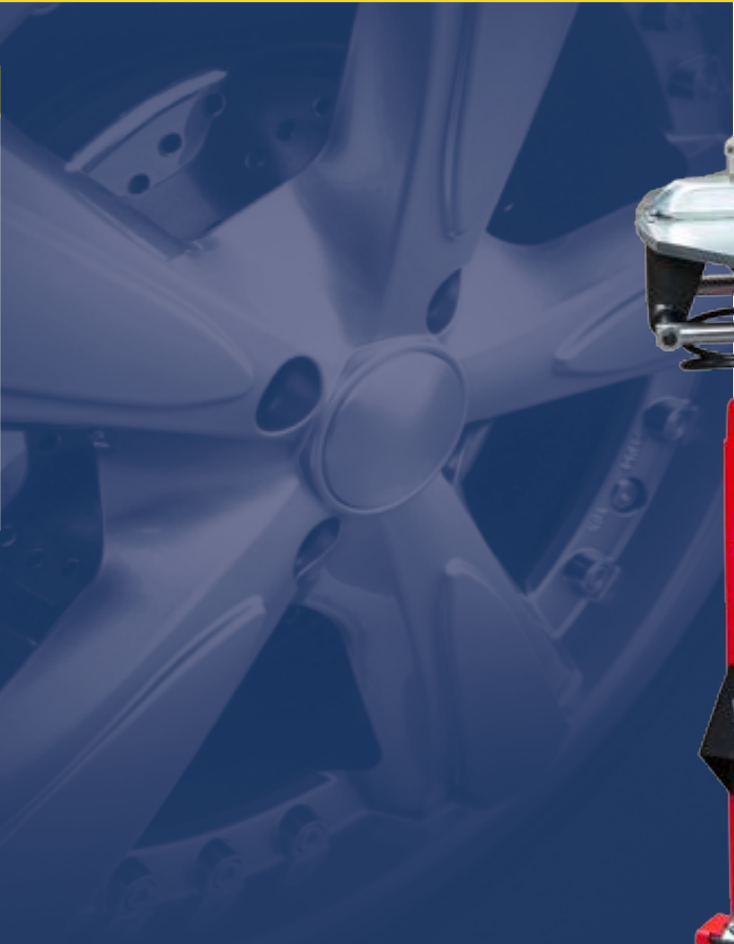

AUTOMATIC
TYRE CHANGER

AUTOMATISCHES
REIFENMONTIERGERÄT



F635



- Automatic tyre changer with **rear tilting post** and simultaneous vertical rod and horizontal arm pneumatic locking system, vertical arm with spring return.
- Automatisches Reifenmontiergerät mit **nach hinten kippbarer Montiersäule**, pneumatischem Simultanblockiersystem des vertikalen Werkzeugarms und des horizontalen Arms, Federrückzug des vertikalen Werkzeugarms.



- Vertical post equipped with **conic bushes** and play recovery systems which allow eliminating post flexure.
- Montiersäule mit **konischen Buchsen** und System, mit dem das Spiel abgefangen und Biegungen an der Säule verhindert werden.

- Self-centring plate with **10-23" locking capacity** and double rotation, equipped with curved connecting rods to ensure a constant locking force throughout different diameters.
- Selbstzentriertisch mit Spannkraft von **10 bis 23 Zoll**, Doppeldrehrichtung, gekrümmten Pleuels zur Beibehaltung einer konstanten Spannkraft bei variierenden Felgendurchmessern.



- **Robust reduction unit**, standard CE-certified inflation pressure limiter with provision for gun connection.
- **Robustes Untersetzungsgetriebe**, serienmäßiger, EU-genormter Befüllungsdruckminderer, der bereits für den Anschluss an die Druckluftpistole gerüstet ist.



Automatic tyre changer ideal for use in professional repair shops and tyre shops. Designed to operate on car and light commercial vehicle wheels and on motorcycle wheels with the appropriate accessories.

Automatisches reifenmontiergerät ideal für profi-werkstätten und reifenhändler, konzipiert für räder von PKW und LLKW und, mit passendem zubehör, für motorradräder.



- Bead breaker with **single-acting cylinder**, ergonomic bead breaker arm and fixed blade.
- Wulstabdrücker mit **Einfacheffekt-Zylinder**, ergonomischem Abdrückarm und fester Abdrückschaufel.

OPTION OPTIONS



- Provision for use of the **side presser** (UHP A22) that facilitates mounting and dismounting of reduced or particularly difficult tyres such as Run-flat or UHP.
- Prädisponiert für die Nutzung des **seitlichen Pressarms** (UHP A22), der dem Bediener die Montage und Demontage von Niederquerschnittsreifen oder besonders schwierigen Rädern wie Run-Flat oder UHP erleichtert.

STANDARD ACCESSORIES - STANDARD ZUBEHÖRTEILE

The machine is supplied standard with a complete set of plastic protections to operate correctly on alloy rims (mounting head, bead breaker blade, bead lifter lever and self-centring plate jaw).

Zur korrekten Bearbeitung von Leichtmetallfelgen ist die Maschine serienmäßig mit einem kompletten Kunststoffschutz-Set ausgestattet (Kopfteil, Abpressschaufel, Montiereisen und Spannklaue des Selbstzentrierisches).



STANDARD FEATURES - TECHNISCHE ANGABEN

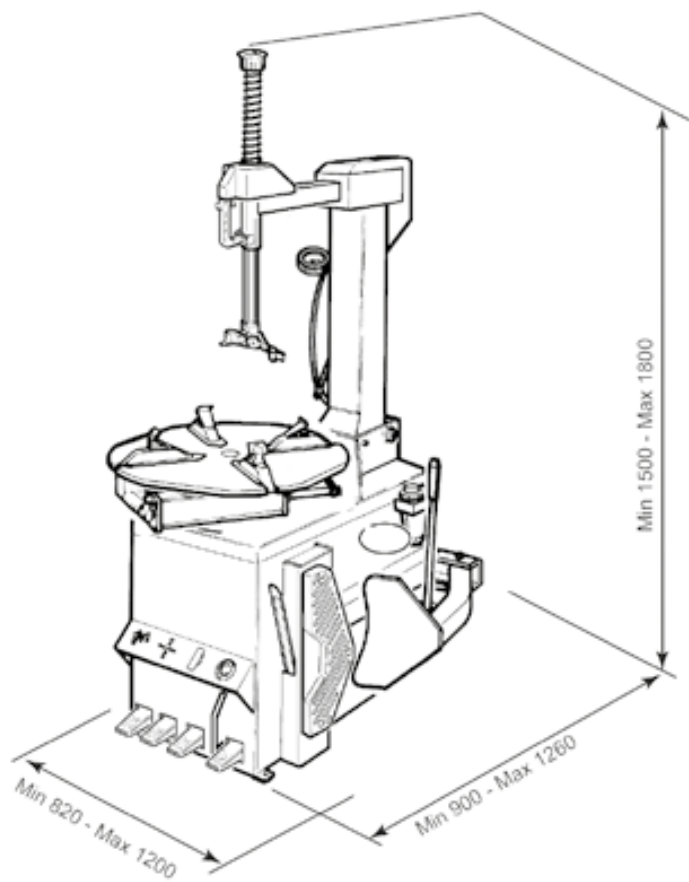

Clamping capacity	10 - 23"
External clamping	10 - 20"
Internal clamping	13 - 23"
Max wheel diameter	1000 mm (39.5")
Max wheel width	320 mm (12.5")
Bead breaker force	2800 Kgf (6175 lbf)
Turntable speed	8 rpm (6-12 rpm 2sp)
3-Phase motor	0.55 kW (0.75 Hp)
1-Phase motor	0.75 kW (1.0 Hp)
Operating pressure	8 - 10 bar (116 - 145 psi)
Noise level	< 70 ± 3 dB (A)
Net weight	205 Kg (450 lbs)
Gross weight	215 Kg (475 lbs)
Packing dimensions	765 x 980 x 970 mm

Spannbereich	10 - 23"
Einspannen aussen	10 - 20"
Einspannen innen	13 - 23"
Maximaler raddurchmesser	1000 mm (39.5")
Maximale radbreite	320 mm (12.5")
Abdrückkraft	2800 Kgf (6175 lbf)
Drehgeschwindigkeit	8 rpm (6-12 rpm 2sp)
Dreiphasenmotor	0.55 kW (0.75 Hp)
Einphasenmotor	0.75 kW (1.0 Hp)
Betriebsdruck	8 - 10 bar (116 - 145 psi)
Sonore geräuschpegel	< 70 ± 3 dB (A)
Nettogewicht	205 Kg (450 lbs)
Bruttogewicht	215 Kg (475 lbs)
Kistenabmessungen	765 x 980 x 970 mm

OPTIONAL ACCESSORIES - OPTIONSZUBEHÖRTEILE

							
UPH A22 - 939005003 x 1	KIT BPS - 939005002 x 1	UWA24 - 939005100 x 4	UMA - 939005101 x 4	KIT AS - 939005021 x 1	RS - 939005054 x 1	CUP - 939005052 x 1	HPG-RF - 939005120 x 1

For more information see the complete brochure - Zu weiteren Informationen siehe unsere ausführliche Broschüre



23826 Mandello del Lario (Lc) - Italy
Tel. +39.0341.706111 - Fax +39.0341.700725
www.focus-1.it

All the data and features mentioned in this catalogue are purely for information and do not constitute any commitment on the part of our company, which reserves the right to make any and all alterations it may consider suitable without notice.